

Goertzel's Algorithm

When DFT is to be computed at selected values of k (frequencies), Direct computation of DFT is more efficient than FFT algorithm.

If the number of DFT points to be computed is less than $\log_2 N$, then Goertzel algorithm is more efficient.

Goertzel algorithm uses linear filtering approach of $x(n)$

$$W_N = e^{-j2\pi / N}$$

$$W_N^{-kN} = e^{-j\frac{2\pi}{N}(-kN)} = e^{j2\pi k} = 1$$

Mrs.Aarti Bang,
VIIT, Pune

$$X(k) = \sum_{m=0}^{N-1} x(m) W_N^{km} \quad \text{DFT Equation}$$

Multiply RHS of above equation with W_N^{-kN}

$$X(k) = \sum_{m=0}^{N-1} x(m) W_N^{km} W_N^{-kN}$$

$$X(k) = \sum_{m=0}^{N-1} x(m) W_N^{-k(N-m)} \text{-----}(1)$$

Above expression is expressed in the form of Convolution

Mrs.Aarti Bang,
VIIT, Pune

$$y_k(n) = \sum_{m=0}^{N-1} x(m) W_N^{-k(N-m)} \text{-----}(2)$$

This equation is convolution of causal sequence $x(n)$ and filter with impulse response W_N^{-kN}

Therefore comparing
eq 1 & 2

$$X(k) = [y_k(n)]_{n=N}$$

Take Z transform of eq 2

$$Y_k(z) = \frac{X(z)}{1 - W_N^{-k} z^{-1}}$$

When $n=N$, o/p of filter $y_k(n)$ is $X(k)$

Mrs.Aarti Bang,
VIIT, Pune

$$y_k(n) = x(n) + W_N^{-k} y_k(n-1)$$

$$H_k(z) = \frac{1}{1 - W_N^{-k} z^{-1}}$$

$$H_k(z) = \frac{1 - W_N^k z^{-1}}{1 - 2\cos\left(\frac{2\pi k}{N}\right)z^{-1} + z^{-2}}$$

Mrs.Aarti Bang,
VIIT, Pune

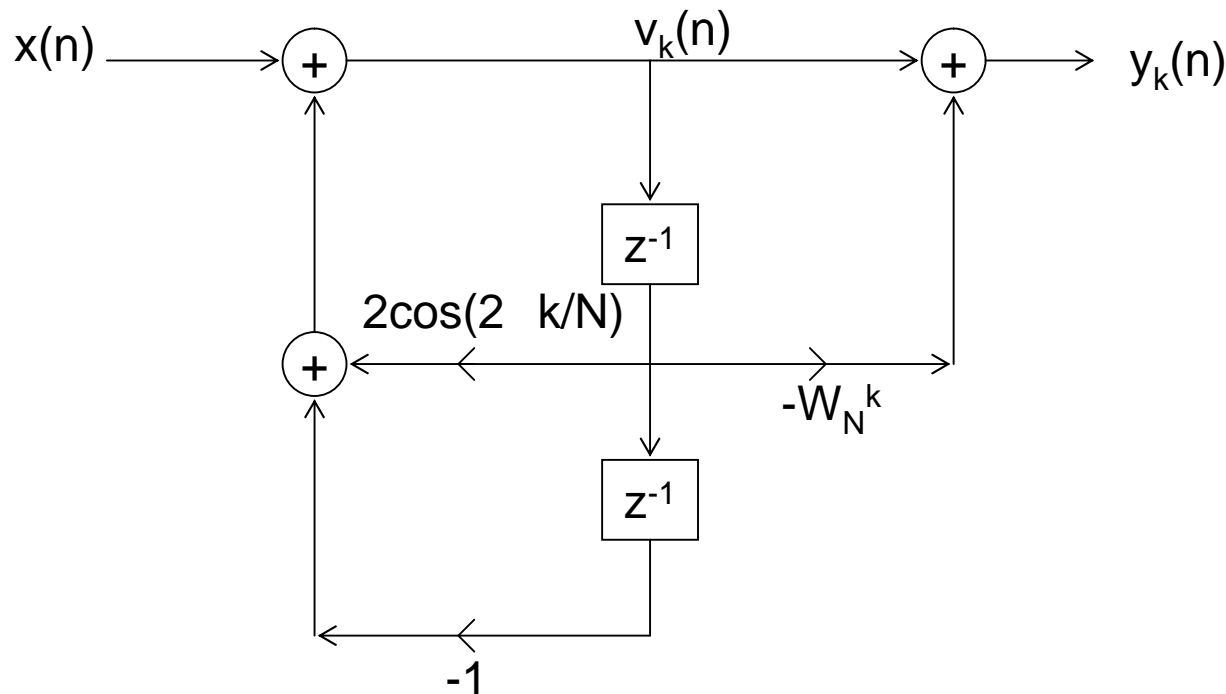

$$v_k(n) = x(n) + 2\cos\left(\frac{2\pi k}{N}\right)v_k(n-1) - v_k(n-2)$$

$$X(k) = y_k(N) = v_k(N) - W_N^k v_k(n-1)$$

Mrs.Aarti Bang,
VIIT, Pune

Application of Goertzel Algorithm : DTMF signal detection

	1209	1336	1477	1633
697 Hz	1	2	3	A
770 Hz	4	5	6	B
852 Hz	7	8	9	C
941 Hz	*	0	#	D

Mrs.Aarti Bang,
VIIT, Pune

Digital implementation involves generation of finite length sequences by using look-up tables.

Tone detection is performed by computing the DFT of the DTMF signal and measuring the energy present at eight DTMF frequencies.

Sampling Frequency : 8 KHz

Minimum duration of DTMF signal is 40 msec.

Thus $0.04 \times 8000 = 320$ samples are available for decoding

Take length = 256 samples. And compute 256 pt. DFT

Mrs.Aarti Bang,
VIIT, Pune

DFT length N determines the frequency spacing between the locations of the DFT samples.

Frequency F_k corresponding to DFT bin number k is given by

$$F_k = \frac{kF_s}{N} \quad k = 0, 1, 2, \dots, N-1$$

Mrs.Aarti Bang,
VIIT, Pune

Basic tone in Hertz	Exact k value	Nearest integer k value
697	22.304	22
770	24.64	25
852	27.264	27
941	30.112	30
1209	38.688	39
1336	42.752	43
1477	47.264	47
1633	52.256	52

Mrs.Aarti Bang,
VIIT, Pune